

SRWF-1022 Wireless Data Module User Manual



Contents

I. Product Introduction	3
II. Application Fields	3
III. Technical specifications	4
IV. Pins Definition	5
V. Channels, Interface Mode and Baud Rate Configuration	6
1. Channel Configuration	6
2. Interface Mode	7
3. Baud Rate	8
4. Parity mode	8
5. Indicator Light	8
6. Timing Diagram	9
VI. Received Signal Strength Indication(RSSI)	10
VII. Layout Dimension	10
VIII. Technical Support and After Service	11

I. Product Introduction

- SRWF-1022 series wireless modules are transparent modules which suit any standard and nonstandard user protocol.
- Active crystal oscillator is used to enable module to work on wide temperature range of -40°C to 80°C
- It has maximum transmit power of 17dBm, 20dBm (5V optional), working on carrier frequency of 433/470MHz.
- High anti-interference ability and low bit error rate (BER): GFSK/FSK modulation with enhanced forward error correction (FEC) encoding technology to ensure resisting ability against pulse interference and random interference.
- Long transmission distance which can reach up to 1200m (@1200bps) with AT-1 antenna placed 2 meters height from the ground in open field.
- Transparent data interface is provided to be applicable with any standard or nonstandard user protocol. False data generated in the air can be filtrated automatically, so that the data received is exactly same as what is transmitted. No more user programming is needed.
- The standard configuration provides 8 channels, which can be extended to 16 or 32 channels to meet users' requirements for multi-channel communication applications.
- COM1 and COM2 serial ports are provided, COM1 is for UART TTL interface, and COM2 is for RS232 and RS485 hardware interfaces which have stronger carrier frequency ability to ensure reliable transmission.
- Interface baud rate is optional 1200/2400/4800/9600/19200bps with data format of 8N1/8O1/8E1/9N1 for user self-definition. No limitation for data frame length to ensure programming flexibility.
- With power supply by 5V DC, the receiving current is 30±3mA; the transmitting current is 90±10mA (17dBm), 100±10mA (20dBm); and the sleeping current is 5±2uA.
- Single chip RF integrated circuit and single chip MCU to simplify peripheral circuits and keep the dimension small, which leads to high reliability and low failure rate.
- Various antennas are available for different application environments.

II. Application Fields

SRWF-1022 series wireless modules are applicable to the following fields:

- Automated Meter Reading (AMR) solution for water, electricity, gas and heat system
- Remote Control for Industry vehicle and lifting machine
- Production line data collecting
- Data communication for railway, oil well, dock and army
- Medical treatments and electric instruments automation control
- Wireless intelligent control for lighting system
- Security alarm, attendance checking and locating for coal mine workers under well
- Car alarm, tire pressure monitoring and four-wheel orientation
- Wireless POS, PDA smart terminals
- Wireless dishes ordering system
- LED display screen for lane buoy or temporary station in open field
- Automated non-stop billing system on freeway
- Wireless crane and electronic scale solution
- Bank queuing management system

III. Technical specifications

Serial number	Description	Parameter	Note
1	Modulation mode	GFSK/FSK	
2	Work frequency	433/470MHz	
3	Transmission power	17dBm, 20dBm(5V optional)	
4	Receiving sensitivity	-117dBm	@1200bps
5	Channel counts	8channel(default)	16/32 channel (customized)
6	Transmitting current	90±10mA (17dBm) 100±10mA (20dBm)	
7	Receiving current	30±3mA	
8	Sleeping current	5±2uA	RS232/S485 hardware interface can't support sleeping function
9	Interface velocity	1200/2400/4800/9600/19200bps	
10	Interface mode	UART TTL/RS-232/RS-485	RS232/S485 hardware interface need to bond different interface chip and peripheral circuits

11	Power supply	+3.3~5VDC	
12	Working temperature	-40℃~80℃	
13	Working humidity	10%~90%(relative humidity, no condensing)	
14	Dimension	47mmx26mmx10mm	
15	Reliable transmit distance	1200m@ AT-1 antenna	2m height, 50mW
		1400m@ AT-1 antenna	2m height, 100mW

IV. Pins Definition

SRWF-1022 provides a 9- pin connector (CON1) defined as below in Table 1.

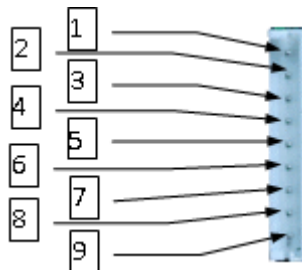

9-pin Connector

Table 1

Pin No	Item	Description	Level	Connected to Terminal	Note
1	GND	Ground of power supply		Grounding of Power Supply	
2	VCC	Power supply DC	+3.3~5.0V		
3	RXD/TTL	Serial data receiving end	TTL	TXD	COM1
4	TXD/TTL	Serial data transmitting end	TTL	RXD	
5	SGND	Ground of the signal			
6	A(TX)	A of RS485 Or TX of RS232		A(RXD)	COM2
7	B(RX)	B of RS485 or RX of RS232		B(TXD)	
8	SLEEP	Sleep control (Input)	TTL	Sleep signal	Low level effective
9	RESET	Reset control (input)	TTL	Reset signal	Negative pulse reset 1ms

V. Channels, Interface Mode and Baud Rate Configuration

There is a 5-bit short-circuit jumper (J1) on the bottom right corner of SRWF-1022 main board, defined as A/B/C/D/E respectively. Please refer to Figure 1.

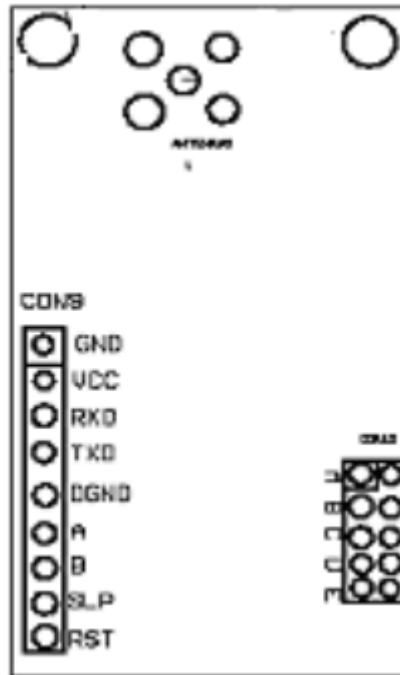









Fig 1

1. Channel Configuration

There are 8 options to set the channel via ABC jumper wires of JP1. The corresponding Frequency of Jumper ABC configuration is shown in table 2.

Table 2

Jumping wire ABC	Channel No.	433MHz band	470MHz band
	0 (ABC remain open)	433.85	470.25
	1	432.10	470.36
	2	433.20	470.49
	3	433.25	470.10

	4	434.00	470.652
	5	432.65	470.842
	6	433.40	470.90
	7	432.60	470.72

2. Interface Mode

SRWF-1022 provides 2 serial ports. COM1 (Pin3 and Pin4) is fixed as UART TTL interface, and COM2 (Pin6 and Pin7) is to choose RS232 and RS485 hardware interface:

a) TTL interface connection

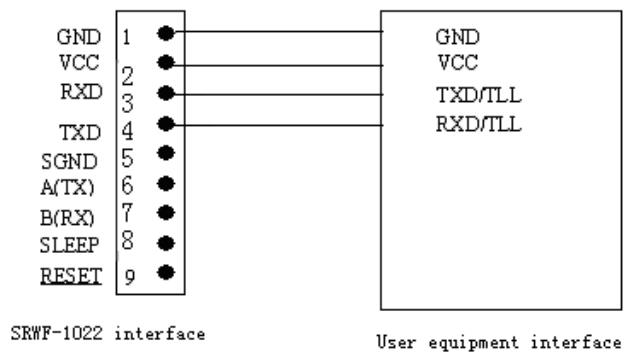

b) RS-232 interface connection

RS232 chip and peripheral circuits will be bonded on the module.

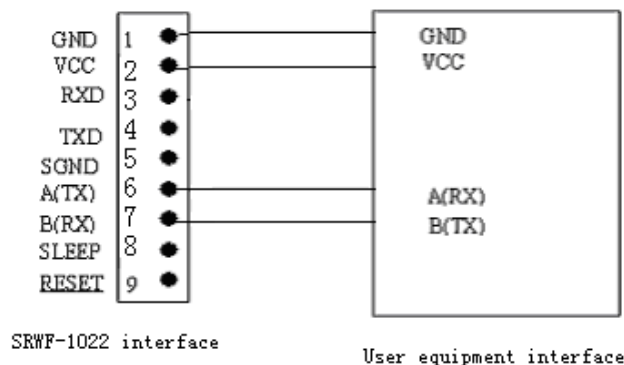

c) RS-485 Interface connection

RS485 chip and peripheral circuits will be bonded on the module.

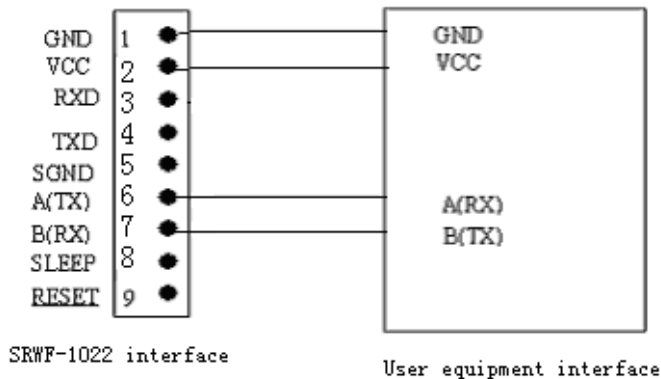

PS: For all the above interface connection, please do not connect any wire on other pins if no use.

3. Baud Rate

The data rate depends on the hardware of wireless module, and it will be fixed after manufacture, so clients have to confirm the baud rate when releasing order.

4. Parity mode

Clients can choose the parity mode via the pin E of J1, means the choice of 8E1/8O1/8N1.

E=0(without jumper ) parity 8E1/8O1/9N1 one parity bit

E=1(with jumper ) parity 8N1 no parity bit

PS: All the above configurations will be effective only when the module is powered again.

5. Indicator Light

TX light will flash once when the module is powered, meaning the module is sending its version information to serial port, by which we can judge some basic status about the module, for example:

SRWF-10221 (V11)

C=00(433), 8N1/9N1

Note: SRWF-10221 means the model is SRWF-1022, and it can communication with SRWF-1021

(V11) indicates that the software version is V1.1

C=00(433), 00 means channel No., and 433 is carrier frequency.

8N1/9N1 is parity mode

When the module is transmitting signals, RX light (red light) will flash.

When the module is receiving signals, TX light (green light) will flash.

6. Timing Diagram

1) Sleeping Mode

The module has sleeping function, controlled by pin SLP. Normally SLP pin is in high level, but when is in low level, the module will start to sleep. The module will not work until RST pin is in low level, means reset, or the module is powered again. Please refer to below sleep/reset timing diagram.

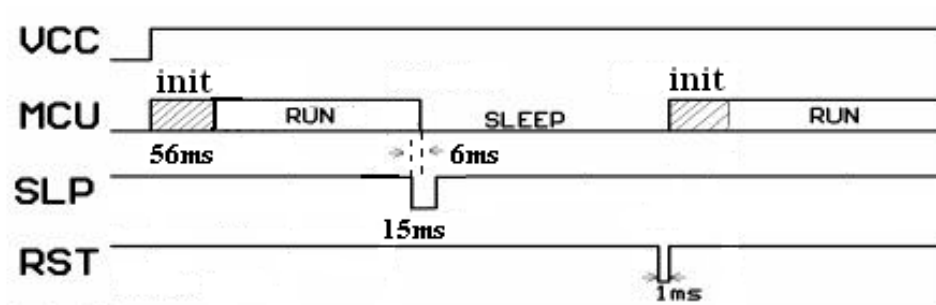

2) Transmitting Delay

Using FEC (Forward Error Correction) technology to enhance anti-interference ability, so there is time delay (T_d) between the data received by RXD of module and the final data exported by TXD of module B. Different data rate results in different delay time. Please check the below time delay diagram.

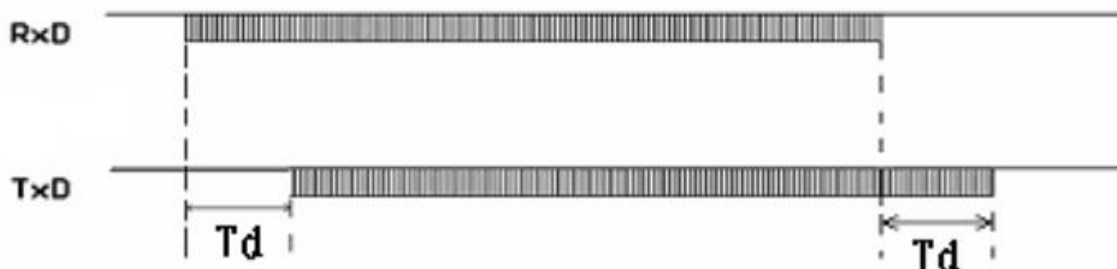

Baud Rate(bps)	Time Delay (Td/ms)
1200	122
2400	58
4800	31
9600	16
19200	8

VI. Received Signal Strength Indication(RSSI)

If you want to detect RSSI, please send REASRSSI to serial port, then the RSSI of previous data frame will be exported, which is indicated with binary complement.

VII. Layout Dimension

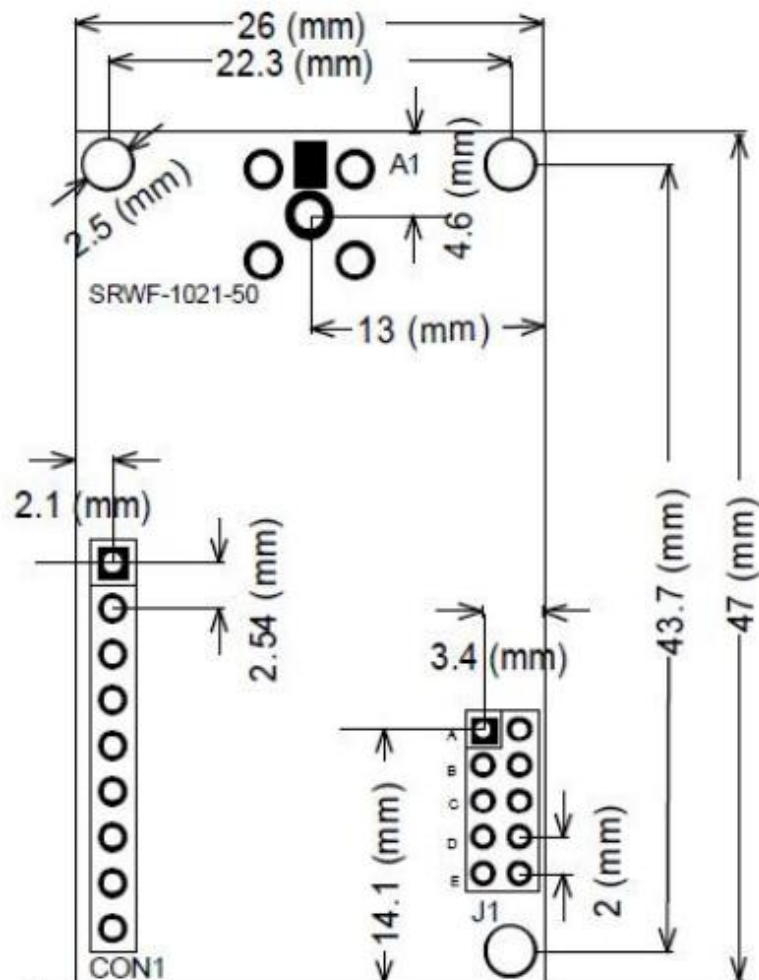

VIII. Technical Support and After Service

We provide full technical support for our clients on applications and secondary development. Our products have one-year warranty and perpetual maintenance services.